

SawStop Quick Start Guide

This saw runs on 110V.

Power switch is Yellow Toggle, flip to on and wait for LEDs to turn solid green before starting motor.

Solid green LED means saw is ready to run with SawStop protection on.

Do not cut any metal or wet conductive woods (Treated lumber can be conductive)

Any conduciveness will set off SawStop safety mechanism. (See Page 8)

Red paddle switch turns on saw blade.

Start dust collector too, before beginning cut.

There is a SawStop safety bypass key switch but it should not be used unless there are very rare extenuating circumstances.

Large pieces such as 4' X 8' sheets require two people to cut safely.

Best practice is to break large sheets into slightly oversize smaller pieces and then trim small pieces to final size.

Please read the next 7 pages of this guide to gain an understanding of the SawStop safety mechanism and the operation of the saw itself.

The full manual is available online and a paper copy is here in the shop.

This SOP compiled by @pberglund

Adjusting the Blade Height

To maximize safety, the height of the saw blade above the table should be as low as possible while still allowing a complete and precise cut. For through-cuts (i.e., cuts where the wood is cut through its entire thickness), the blade height should be adjusted so that the top of the blade is no more than $\frac{1}{8}$ inch to $\frac{1}{2}$ inch above the workpiece.

The blade can be adjusted from $\frac{1}{8}$ inch below the table top to $3\frac{1}{8}$ inch above the table top. To adjust the height of the blade, loosen the elevation lock knob and turn the elevation handwheel until the blade is at the desired height. Turn the handwheel clockwise to raise the blade, and counter-clockwise to lower the blade. Lock the blade height by turning the elevation lock knob clockwise until tight.

The saw includes limit stops to prevent the height of the blade from being adjusted past the maximum and minimum set points. The upper limit stop is adjustable and pre-set at the factory. It should not need further adjustment but if you decide to adjust the upper blade elevation limit stop, see page 74 of full manual for instructions.

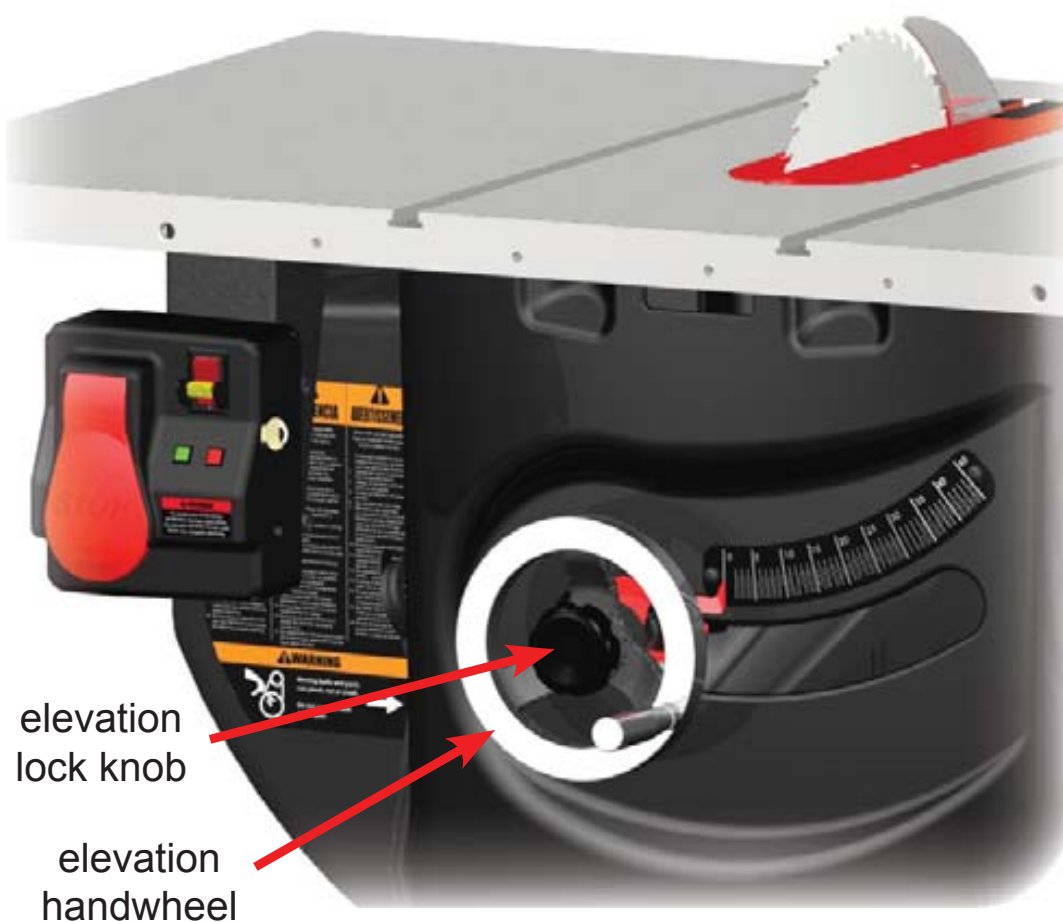
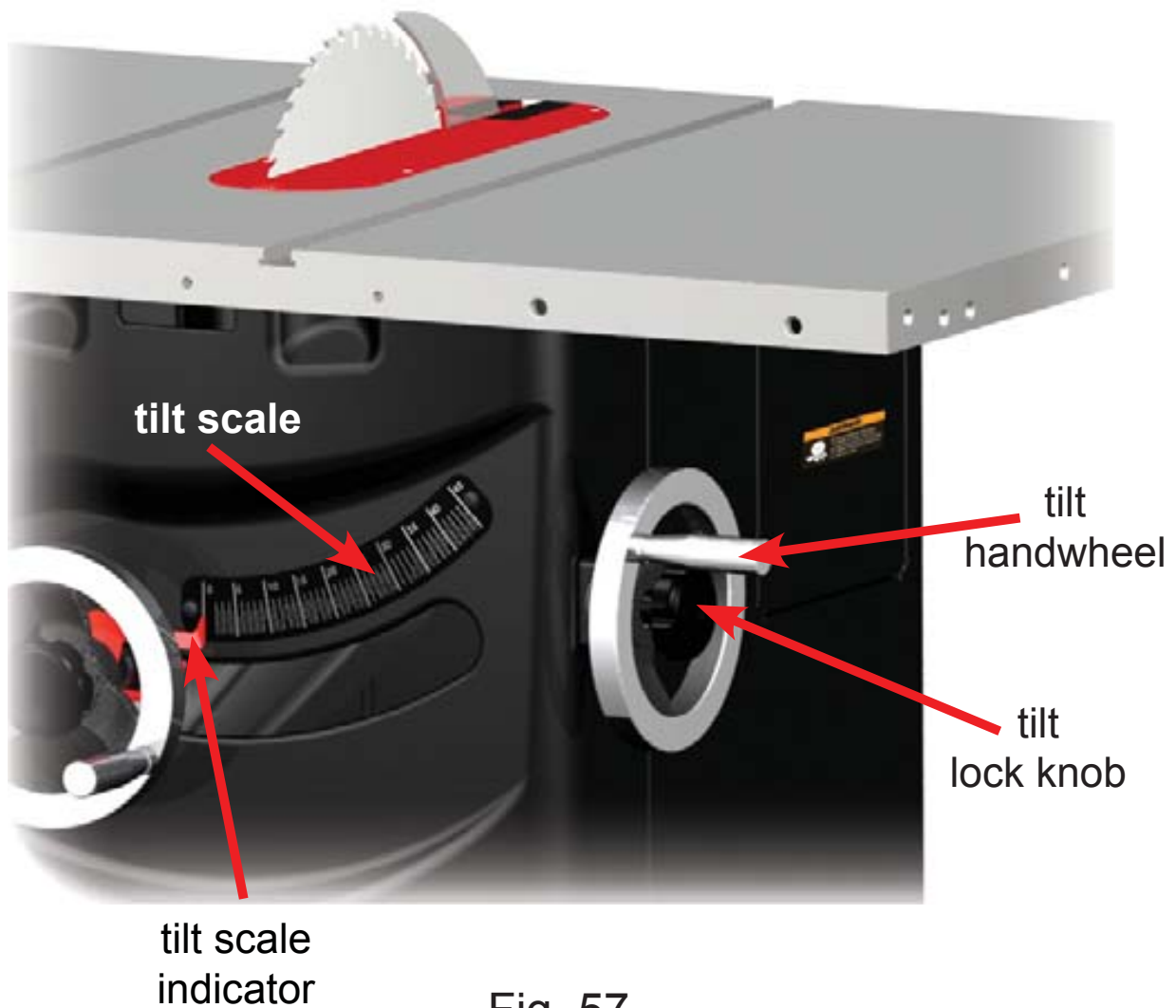

Fig. 56

Adjusting the Blade Tilt Angle

The tilt (bevel) angle of the blade can be adjusted between 0° and 45°. To adjust the tilt angle of the blade, loosen the tilt lock knob and turn the tilt handwheel until the blade is at the desired angle. The tilt angle of the blade is indicated by the position of the tilt angle indicator on the tilt angle scale. Turn the tilt handwheel counter-clockwise to increase the tilt angle, and clockwise to decrease the tilt angle. Lock the tilt angle by turning the tilt lock knob clockwise until tight.

The saw includes limit stops to prevent the tilt angle from being adjusted past the 0° and 45° set points. These limit stops are pre-set at the factory and should not need adjustment. If you decide to adjust the blade tilt limit stops, see page 75 of full manual for instructions.



Turning on Main Power and Starting the Motor

Your *SawStop*[®] saw is equipped with a main power switch to supply power to the *SawStop*[®] safety system and a Start/Stop paddle to turn the motor on and off.

Both the main power switch and the Start/Stop paddle are mounted on the switch box (see Fig. 58).

To start your saw, first make sure the Start/Stop paddle is in the **“OFF”** position (i.e., pushed in) and then turn the main power switch to the **“ON”** position by flipping the toggle upward. This will turn on power to the *SawStop*[®] safety system, and the system will run through a brief initialization routine to test whether the system is operating properly. During this initialization period (approximately 5–10 seconds), red and green lights on the switch box may blink in different patterns as the safety system runs through various self-check steps. These lights are light-emitting diodes (LEDs) and they display the current status of the safety system and saw. Once the safety system completes the initialization routine, the LEDs will display the **“READY”** status display (green LED on solid, red LED off). The saw is now ready for use.



To start the motor, pull the Start/Stop paddle out. To stop the motor, push the Start/Stop paddle in. The paddle is designed so that it can be pushed in by the operator's upper leg or knee in an emergency.

If the READY status is not displayed after 15 seconds, the safety system has detected an error that must be corrected before the saw can be used. See page 6 for a key to the LED status codes and an explanation of the error detected for each code. A label describing the LED displays is also positioned on the side of the switch box.

It is not necessary to turn off the main power switch after pushing in the Start/Stop paddle to turn off the motor. If you plan to make several cuts with the saw, you can leave the main power switch in the **ON** position between cuts to eliminate the delay due to the initialization routine. Once you have finished using the saw, turn the main power switch to **OFF** to reduce the likelihood of inadvertent start-up.

In addition, the main power switch has a lockout key that you can remove to prevent children or other non- authorized users from turning the saw on. To remove the key, pull it out, away from the switch. To replace the key, press it back into the socket until it snaps into place. When the key is removed, the main power switch can be turned **OFF**, but it cannot be turned **ON**.



Fig. 59

Your saw also comes equipped with a thermal overload switch that will cut power to the motor if the motor starts to overheat. The motor could overheat, for example, if it is overloaded or if a workpiece is fed too rapidly into the blade.

If the thermal overload switch cuts power to the motor, wait a minute or two for the motor to cool down to a safe operating temperature and then push the red thermal overload reset button on the contactor box behind the left side of the switch box. An audible click will indicate that the thermal overload switch has been reset and the saw is ready to use. Double check the electrical circuit and all electrical connections and always use an appropriate feed rate for the material that you are cutting.









System Status Codes

The LED lights on the front of the switch box display the current status of the safety system. Each light may be off, or may be on, and if it is on, it may be blinking slowly, blinking quickly, or not blinking at all, which we call “on solid.” Together, the red and green lights display a code, referred to as the System Status Code, which tells you if the saw is operating normally or if there is a problem. When you first turn the Main Power switch on, the safety system will complete an initialization routine to verify the safety system is operating normally.

SawStop		
System Status Codes		
Grn	Red	Status
—	- - - -	System Initializing
—		System Ready
	—	Replace Cartridge
•••••		Coasting Down
- - -		Bypass Mode On
•••••	•••••	Push Start/Stop Paddle To OFF
	- - -	Turn Cartridge Key To ON
•••••	—	No Blade Rotation See Manual
- - -	—	Adjust Position of Brake Cartridge
—	•••••	Contact Detected During Standby
- - -	•••••	Contact Detected During Bypass
	•••••	Overload Due To Wet Wood

After the initialization routine is completed, you should not see the red light unless there is a System Status problem. If this happens, find the System Status code below (see Fig. 61) to determine how to correct the problem.

Symbol Key

-  Green LED blinks fast
-  Green LED blinks slowly
-  Green LED is on solid
-  Red LED blinks fast
-  Red LED blinks slowly
-  Red LED is on solid

WARNING! Always turn off the main power switch and unplug the power cord before performing adjustments or maintenance to the saw.

Fig. 61

System Initializing — this code indicates that the system is performing self-checks and energizing the brake system to activate in the case of an accident. This condition should clear within 15 seconds after the main power switch is turned on. If the ambient temperature is very low (below about 0° F), this code may take longer to clear. The safety system detects such low temperatures within the brake cartridge. If necessary, the system turns on a heater inside the cartridge to raise the temperature of the electronics. This code will continue until the temperature inside the brake cartridge is within the normal operating range.

System Ready — this code indicates that all self-checks have been completed, the safety system is operating properly, and the saw is in Standby mode ready to run.

Replace Cartridge — this code indicates that the brake cartridge has fired or there is some other permanent defect that cannot be corrected. If the cartridge has not been fired, turn off the main power and turn it back on. If the error continues, install a new cartridge.

Coasting Down — this code indicates that the blade is coasting down and that the safety system is ready to activate the brake if contact is detected. The safety system monitors the rotation of the blade while it is coasting down. If you touch the blade while this code is flashing, the brake will activate.

ALWAYS MAKE SURE THE BLADE HAS COME TO A COMPLETE STOP AND THE COAST DOWN STATUS CODE HAS CLEARED BEFORE TOUCHING THE BLADE!

Bypass Mode ON — this code indicates that the saw is running in Bypass Mode and **will not** activate the brake in the event of accidental contact with the blade. Bypass Mode allows you to cut electrically conductive materials such as aluminum without activating the brake. When the saw is in Bypass Mode, the safety system disables the brake. See page 57 for instructions on how to use the saw in Bypass Mode.

Push the Start/Stop Paddle to OFF — this code indicates that the Start/Stop paddle was in the *ON* position (i.e., pulled out) before the main power switch was turned on. Push the paddle in to the *OFF* position to clear this error. This is a safety feature to prevent the saw from restarting after a power loss or after the safety system has turned the saw off due to an error detected during use.

Turn Cartridge Key to ON — this code indicates that the cartridge locking key is not turned to *ON*. To clear this error first turn the main power switch to *OFF*, and then make sure the cartridge locking key is correctly installed and turned to *ON*. See page 63 for instructions on how to install and turn on the cartridge key.

No Blade Rotation — this code indicates that the motor is not able to spin the blade as expected. In most cases this is because the thermal overload switch has cut power to the motor to prevent overheating. If the thermal overload switch cut power to the motor, wait a minute or two for the motor to cool down to a safe operating temperature and then push the red thermal overload reset button on the contactor box behind the left side of the switch box. An audible click will indicate that the thermal overload switch has been reset and the saw is ready to use. This error code may also indicate that the motor belt is broken and must be replaced.

Adjust Position of Brake Cartridge — this code indicates that the blade is either too far from or too close to the brake cartridge. To clear this error first turn the main power switch to *OFF*, and then adjust the position of the brake cartridge as described on page 30. This error code will also be displayed if there is no blade installed, if a blade smaller than 10 inches is installed, or if a non-conductive blade (e.g. abrasive blade) is installed.

Contact Detected During Standby — this code indicates that the safety system detected contact with the blade (or a portion of the arbor) when the blade was not spinning. This code will be displayed if you come into contact with the blade or arbor while the system is in Standby mode. The brake will not be activated and the code will automatically clear within 5 seconds after contact is ended. The system will not allow the motor to start while this code is displayed.

Contact Detected During Bypass — this code indicates that contact was detected while the saw was running in Bypass Mode. As described above, the brake will not activate while in Bypass Mode but the safety system will continue to monitor for contact. If this code is displayed, then it indicates that the brake would have activated if the system had not been in Bypass Mode. This error will automatically clear once the blade has finished coasting down.

Material Conductivity Test

The “Contact Detected During Bypass” code also allows you to test a particular material to see if it is too conductive to cut during normal operation. For example, if you have a new material you need to cut and are not sure if it is conductive, you can make several cuts in Bypass Mode. If the “Contact Detected During Bypass” error code is displayed, it means the material is too conductive and must be cut in Bypass Mode to prevent the brake from activating. If the error code is not displayed after several trial runs, then it is likely that the material is not conductive and you can make future cuts in normal mode. (See page 57 for instructions on how to operate the saw in Bypass Mode.)

Overload Due to Wet Wood — this code indicates that the wood being cut is too wet or too green. You can cut most wet or green wood with the safety system active. However, extremely wet or green wood can interfere with the safety system’s ability to detect contact. Accordingly, the system monitors for wet and green wood and, if the wood is too wet or too green, the system will shut off the motor and display this error code. To clear this error, turn the Start/Stop paddle to *OFF* and turn the main power switch to *OFF* and then back to *ON*.

In addition, wet pressure-treated wood may cause an overload error or even cause the brake to activate. The chemicals used to pressure treat wood often contain large amounts of copper, which is conductive. When pressure-treated wood is wet, the combination of copper and water substantially increase the conductivity of the wood. Therefore, allow wet pressure-treated wood to fully dry before cutting. Typically, the wood will be sufficiently dry if left unstacked in a dry location for 24 hours. If you must cut wet pressure-treated wood, you can use the Material Conductivity Test described above to test whether the wood is too wet. If the test indicated the wood is too wet to cut with the safety system active, you must either allow the wood to dry or make the remaining cuts in Bypass Mode.

Note: if the saw shuts down due to an overload error, do not attempt to finish cutting that piece of wood until it has dried. The overload error indicates that the system was close to firing the brake before it went into overload. Therefore, repeatedly attempting to cut a wet piece of wood could result in an unnecessary activation of the brake.