

Grizzly Drill Press SOP

Drill Press is wired to run on 110V.

Drill Press has a built in light with a ON/OFF switch.

Never hold a workpiece by hand while drilling.
Clamp it down or hold it in a vice.

Never drill sheet metal without it being clamped securely.

Different bits and different materials drill best at certain speeds.
There is a Bit/Material/Speed chart on Page 5 of this guide.
Familiarize yourself with how to change speeds on the Drill Press.
Page 6 of this guide shows how to change speeds.
Full speed chart is under pulley cover on Drill press

Please read the next 8 pages of this guide to gain an understanding of the operation of the Drill Press itself.

The full manual is available online and a paper copy is here in the shop.

This SOP compiled by @pberglund

Identification

Refer to the list below and see **Figures 1 & 2** to become familiar with the drill press controls.

1. **Light Switch:** Turns light **ON/OFF**.
2. **Power Switch:** Turns motor **ON/OFF**.
3. **Belt Tension Lever:** Adjusts motor location to increase/decrease belt tension.
4. **Belt Tension Lock:** Locks motor in place.
5. **Table Height Crank:** Raises/lowers table.
6. **Table Lock Lever:** Locks table rotation.
7. **Column Lock Lever:** Locks table height.
8. **Torsion Spring:** Returns quill into headstock.
9. **Lash Screw:** Removes quill lash.
10. **Depth Stop:** Limits quill travel to a pre-set drilling depth.
11. **Scale:** Displays current table-tilt angle.

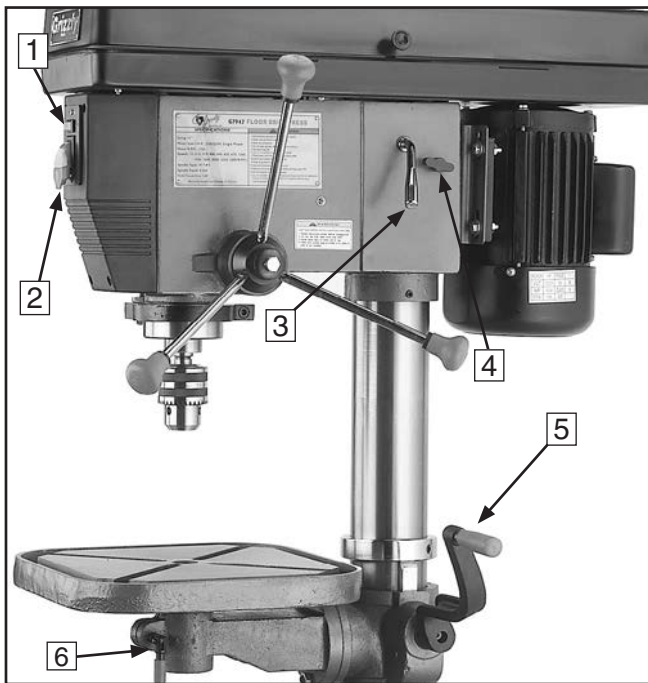

Figure 1. Right-side controls.

Refer to the list below to become familiar with the drill press terms and definitions.

Headstock: The cast iron upper portion of the drill press, which houses the quill and work light, and supports the motor and belt housing.

Drift Key: A wedge-shaped tool used to separate tapers.

T-Slot: A slot in a table used to trap a hex nut or hex bolt to clamp down a workpiece or a vise.

Arbor: A tapered shaft that connects the chuck to the spindle.

Quill: Houses the spindle and bearings.

Spindle: The hollow shaft that accepts the arbor.

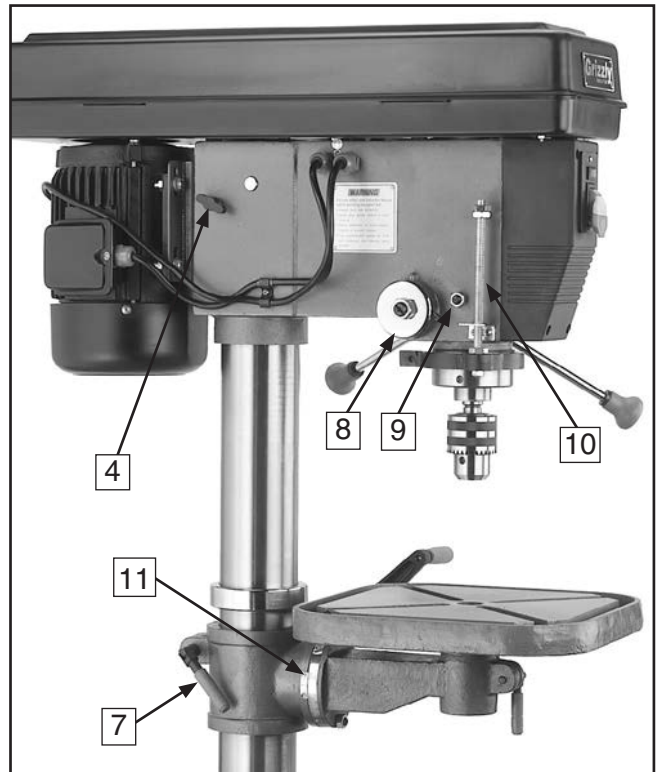

Figure 2. Left-side controls.

WARNING

Safety for Drill Presses

- 1. EYE/FACE/HAND PROTECTION.** A face shield used with safety glasses is recommended. Always keep hands and fingers away from the drill bit. Never hold a workpiece by hand while drilling! **DO NOT** wear gloves when operating the drill.
- 2. SECURING BIT.** Properly tighten and securely lock the drill bit in the chuck.
- 3. CORRECT BIT.** Use only round, hex, or triangular shank drill bits.
- 4. ADJUSTING KEYS AND WRENCHES.** Remove all adjusting keys and wrenches before turning the machine **ON**.
- 5. DRILLING SHEET METAL.** Never drill sheet metal unless it is securely clamped to the table.
- 6. SURFACE/WORKPIECE PREP.** Never turn the drill press **ON** before clearing the table of all objects (tools, scrap wood, etc.) **DO NOT** drill material that does not have a flat surface, unless a suitable support is used.
- 7. DAMAGED TOOLS.** Never use tools in poor condition. Dull or damaged cutting tools are hard to control and may cause serious injury.
- 8. DRILL OPERATION.** Never start the drill press with the drill bit pressed against the workpiece. Feed the drill bit evenly into the workpiece. Back the bit out of deep holes.

Turn the machine **OFF** and clear chips and scrap pieces with a brush. Shut power **OFF**, remove drill bit, and clean table before leaving the machine.
- 9. OPERATING SPEED.** Always operate your drill press at speeds that are appropriate for the drill bit size and the material that you are drilling.
- 10. MAINTENANCE/SPEED CHANGES.** Never do maintenance or change speeds with the machine plugged in.
- 11. MOUNTING WORKPIECES.** Use clamps or vises to secure workpiece before drilling. Position work so you avoid drilling into the table.
- 12. TABLE LOCK.** Make sure the table lock is tightened before starting the drill press.
- 13. EXPERIENCING DIFFICULTIES.** If at any time you are experiencing difficulties performing the intended operation, stop using the machine! Contact our Service Department at (570) 546-9663.

WARNING

Like all machines there is danger associated with this machine. Accidents are frequently caused by lack of familiarity or failure to pay attention. Use this machine with respect and caution to lessen the possibility of operator injury. If normal safety precautions are overlooked or ignored, serious personal injury may occur.

CAUTION

No list of safety guidelines can be complete. Every shop environment is different. Always consider safety first, as it applies to your individual working conditions. Use this and other machinery with caution and respect. Failure to do so could result in serious personal injury, damage to equipment, or poor work results.

SECTION 4: OPERATIONS

Operation Safety

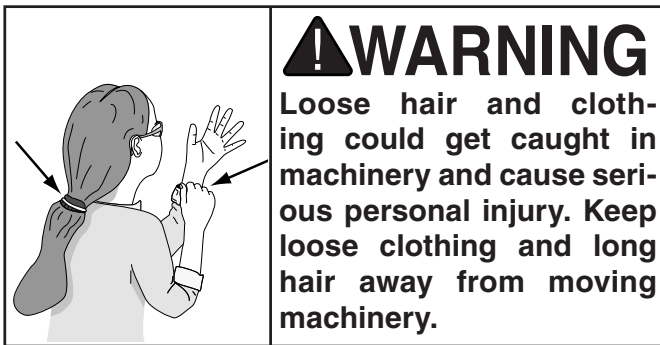

NOTICE

If you have never used this type of machine or equipment before, WE STRONGLY RECOMMEND that you read books, trade magazines, or get formal training before beginning any projects. Regardless of the content in this section, Grizzly Industrial will not be held liable for accidents caused by lack of training.

Installing/Removing Drill Bits

Any drill bit you install in the chuck must be tight enough that it will not come loose during operation.

To install a drill bit:

1. UNPLUG THE DRILL PRESS!
2. Open the drill chuck wide enough to accept the shank of the drill bit.
3. Insert the drill bit as far as possible into the chuck WITHOUT allowing the chuck jaws to touch the fluted portion of the bit, and hand tighten the chuck.

Note: Make sure small bits are not trapped between the edges of two jaws; if they are, reinstall the drill bit or it will not be secure enough to use for drilling.

4. Final tighten the drill bit with the chuck key.

To remove a drill bit:

1. UNPLUG THE DRILL PRESS!
2. Use the chuck key to open the drill chuck, and catch the drill bit with a rag to protect your hands.

Choosing Speeds

Using the Drill Bit Speed Chart

The chart shown in **Figure 25** is intended as a guide only. Always follow the manufacturer's speed recommendations if provided with your drill bits, cutters, or hole saws. Exceeding the recommended speeds may be dangerous to the operator.

The speeds shown here are intended to get you started. The optimum speed will always depend on various factors, including tool diameter, drilling pressure, material hardness, material quality, and desired finish.

Often, when drilling materials other than wood, some type of lubrication is necessary.

Lubrication Suggestions

WoodNone
 Plastics Soapy Water
 Brass Water-Based Lubricant
 Aluminum.....Paraffin-Based Lubricant
 Mild Steel.....Oil-Based Lubricant

CAUTION

Larger bits turning at slower speeds tend to grab the workpiece aggressively. This can result in the operator's hand being pulled into the bit or the workpiece being thrown with great force. Always clamp the workpiece to the table to prevent injuries.

Twist/Brad Point Drill Bits	Soft Wood	Hard Wood	Plastic	Brass	Aluminum	Mild Steel
1/16" – 3/16"	3000	2500	2500	2500	3000	2500
13/64" – 3/8"	2000	1500	2000	1250	2500	1250
25/64" – 5/8"	1500	750	1500	750	1500	600
11/16" – 1"	750	500	1000	400	1000	350

Spade/Forstner Bits	Soft Wood	Hard Wood	Plastic	Brass	Aluminum	Mild Steel
1/4" – 1/2"	2000	1500				
9/16" – 1"	1500	1250				
1-1/8" – 1-7/8"	1000	750				
2–3"	500	350				

Hole Saws	Soft Wood	Hard Wood	Plastic	Brass	Aluminum	Mild Steel
1/2" – 7/8"	500	500	600	600	600	500
1" – 1-7/8"	400	400	500	500	500	400
2" – 2-7/8"	300	300	400	400	400	300
3" – 3-7/8"	200	200	300	300	300	200
4" – 5"	100	100	200	200	200	100

Rosette Cutters	Soft Wood	Hard Wood	Plastic	Brass	Aluminum	Mild Steel
Carbide Insert Type	350	250				
One-Piece Type	1800	500				

Tenon/Plug Cutters	Soft Wood	Hard Wood	Plastic	Brass	Aluminum	Mild Steel
3/8" – 1/2"	1200	1000				
5/8" – 1"	800	600				

Figure 25. Drill bit speed chart.

Changing Speeds

The belts in the head of the drill press must be rearranged to change speeds. A chart under the belt cover shows the belt positions needed to make the drill press run at the desired speed.

To change speeds:

1. UNPLUG THE DRILL PRESS!
2. Loosen the belt tension lock knobs (shown in **Figure 26**) on both sides of the headstock, so the motor is free to move.

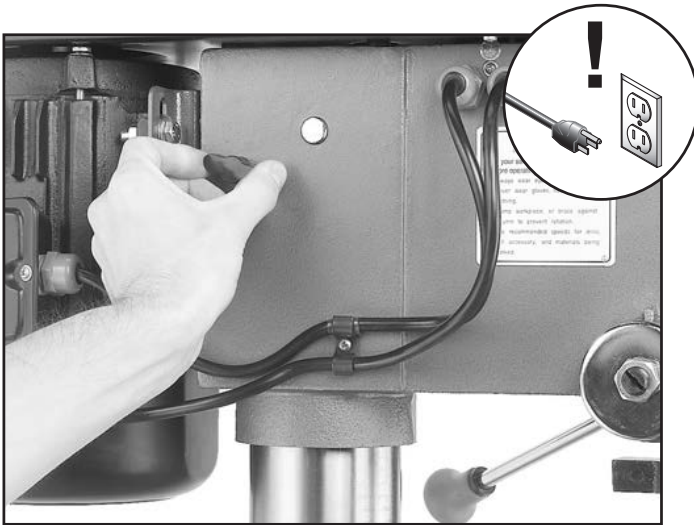

Figure 26. Loosening lock knob (both sides).

3. Rotate the belt tension lever clockwise, as shown in **Figure 27**, to take tension off the V-belts.

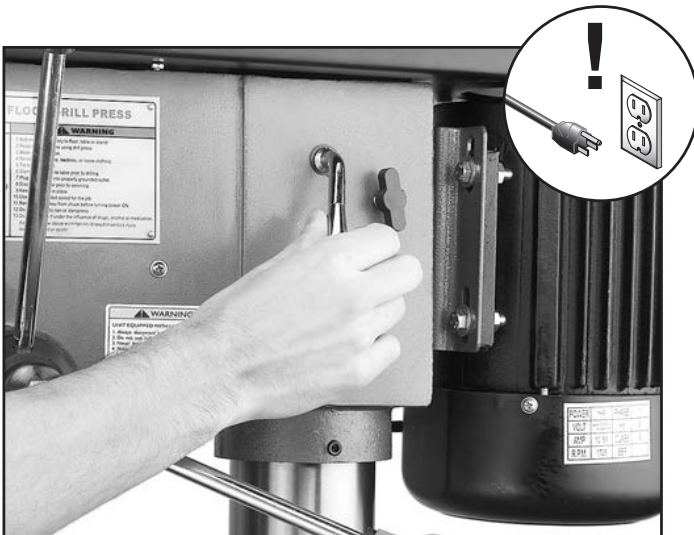

Figure 27. Using the belt tension lever.

4. Locate the desired speed on the speed chart under the belt cover and move the V-belts to the desired V-grooves on the motor, idler, and spindle pulleys.

For Example: As indicated in the speed chart for **670 RPM (Figure 28)**, a belt combination of **A-1.2-2** creates 670 RPM.

- The “**A-1**” refers to the belt position between the spindle pulley and the idler pulley.
- The “**2-2**” refers to the belt position between the motor pulley and the idler pulley.

Note: Both belts may have to be removed before certain speed changes can be made.

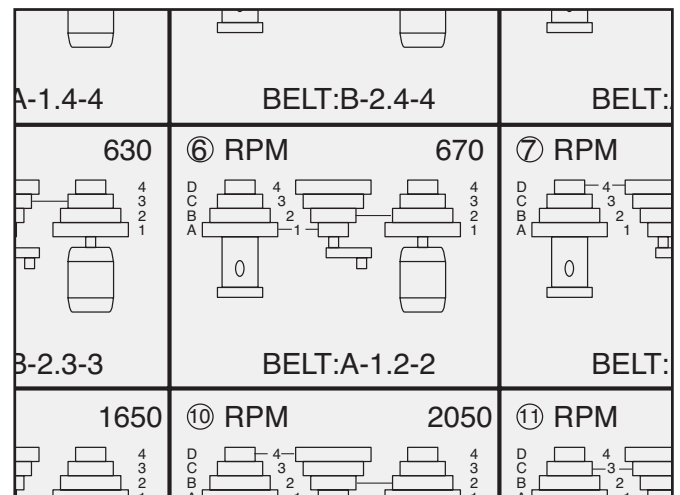

Figure 28. Pulley combination for 670 RPM for example.

5. Rotate the belt tension lever until the belts are tight. Tighten both lock knobs.
6. Close the cover before plugging in the machine.

Drilling

The Model G7947/G7948 is designed for drilling holes in wood or metal. The basic operation of a drill press is lining up your drill bit with the intended hole location, turning the drill press **ON**, and using the down feed levers to move the spinning drill bit into the workpiece.

For safe operation and optimum results, it is very important to follow these guidelines when drilling:

CLEARING CHIPS: Raise the drill bit often to clear chips and cool the drill bit. This will ease the work of the drill press motor and extend the life of your drill bits.

SECURING WORKPIECE TO TABLE: Secure the workpiece to the table or in a vise that is secured to the table before drilling.

PROTECTING TABLE: Protect the table by placing the workpiece on scrap wood, or center the location of the hole to be drilled over the pocket in the table when through drilling. Also, make use of the depth stop so that the drill bit goes no deeper than necessary.

USING CORRECT SPEEDS: Use the correct speed for the diameter of the drill bit being used and the type of material being drilled. Refer to the **Drill Bit Speed Chart** on **Page 27** to help you choose the correct speed for your application.

LARGE DIAMETER BITS: Large diameter drill bits require slower spindle speeds.

SMALL DIAMETER BITS: Smaller diameter drill bits require faster spindle speeds.

HARD MATERIAL: The harder the material, (steel vs. wood) the slower the spindle speed.

SOFT MATERIAL: The softer the material, the faster the spindle may turn. (Plastics can melt at too high of a spindle speed!)

LUBRICANT: Use some form of lubricant on all materials except wood. Refer to **Lubrication Suggestions** on **Page 27** to find the correct lubrication for your application.

DRILLING ACCURACY: To prevent drill bit wandering and ensure accurate placement of holes, mark the hole location with a center punch before drilling. Also consider using a center-point drill to start the hole.

PLUG/ROSETTE CUTTERS: Plug cutters and rosette cutters are for wood only. However, carbide-tipped bits and cutters cut at a higher speed and can cut materials other than wood, depending on the cutter type.

5-FLUTE/2-FLUTE CUTTERS: Use a 5-flute cutter when cutting into plastics, brass, aluminum, and mild steel. A 2-flute cutter can aggressively grab the workpiece and damage the tool if used with materials other than wood.

SPADE BITS AND PLASTIC: When drilling plastic with a spade bit, use a spade bit with spurs.

HOLE SAWS: When using hole saws, apply firm and even pressure, so the saw teeth contact the surface all at the same time—not at an angle. You can also flip the workpiece and finish drilling from the other side.

CAUTION

Larger bits turning at slower speeds tend to grab the workpiece aggressively. This can result in the operator's hand being pulled into the bit or the workpiece being thrown with great force. Always clamp the workpiece to the table to prevent injuries.

Depth Stop

The Model G7947/G7948 has a depth stop that allows you to drill repeated non-through holes to the same depth every time.

The depth stop consists of a stud attached to the quill with two hex nuts that can be lowered or raised on the stud so the lower nut (depth nut) hits a stop bracket when the drill bit is lowered. The upper hex nut (jam nut) is then used to tighten against the depth nut to secure it in place so it doesn't move with repeated operations. **Figure 29** shows the various components of the depth stop.

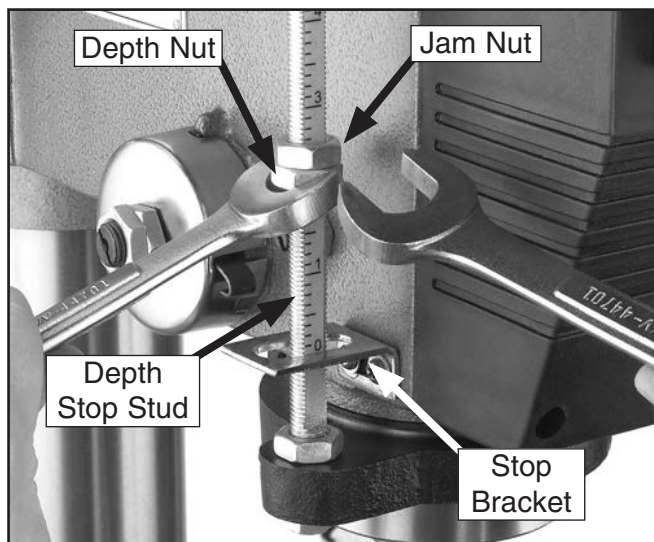

Figure 29. Depth stop components.

To set the depth stop:

1. Lower the drill bit to the required height.
2. Thread the depth nut down against the stop bracket.
3. Lower the jam nut against the depth nut.
4. Using wrenches, hold the depth nut in place and tighten the jam nut against the depth nut.

Note: The scale on the depth stop can be recalibrated if it gets moved or has changed since the factory setting. Refer to **Calibrating Depth Stop** on **Page 38** for instructions on how this is done.

Adjusting Table

The table can be raised/lowered, rotated, and tilted 90° left or right. Table adjustment controls are shown in **Figure 30**.

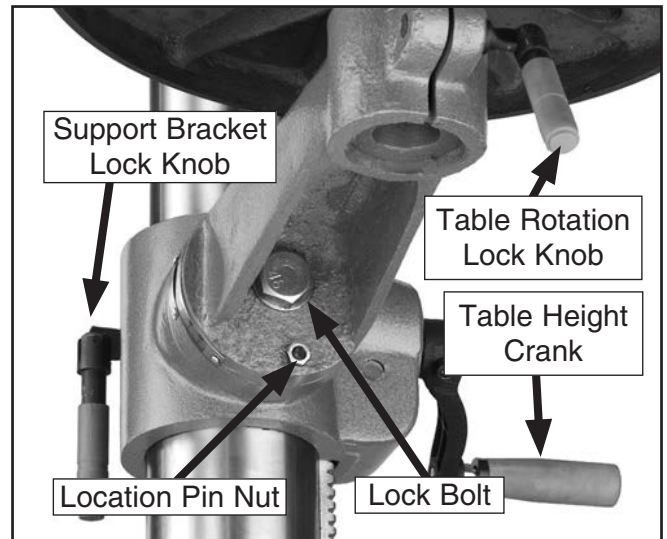

Figure 30. Table adjustment controls.

Table Height

1. Loosen the support bracket lock knob.
2. Adjust the height.
3. Lock the support bracket lock knob.

Table Rotation

1. Loosen the table rotation lock knob.
2. Rotate the table as necessary.
3. Lock the table rotation lock knob.

Table Tilt

1. Tighten the location pin nut to draw the location pin out of the hole. **Note:** The location pin is friction fit in the hole to lock the table at 0°. When reinstalling, set the table to 0°, back the nut off, and tap the pin back in the hole.
2. Loosen the lock bolt and tilt the table to the desired angle (make sure table rotation lock knob is locked, so the table won't fall out).
3. Tighten the lock nut bolt.

Arbor Removal

The arbor can be removed to install other Morse Taper tooling in the spindle. A drift key is included to help remove the arbor or other tooling from the spindle. Usually, once the chuck and arbor have been properly mounted together, they are considered semi-permanent connections. (If you would like to install a different chuck, we recommend getting a new arbor for that chuck.)

To remove the drill chuck and arbor:

1. UNPLUG THE DRILL PRESS!
2. Rotate the spindle handles until the drift-key slot is exposed in the side of the quill.
3. Rotate the depth stop hub clockwise until it stops.
4. Tighten the lock knob. The quill should not return up into the head casting when the depth stop is adjusted this way.
5. Rotate the spindle until the inner drift-key slot is aligned with the outer slot, as shown in **Figure 31**. You will see through the spindle when the slot is properly aligned.
6. Insert the drift key into the drift-key slot, and allow the quill to rise, trapping the drift key.

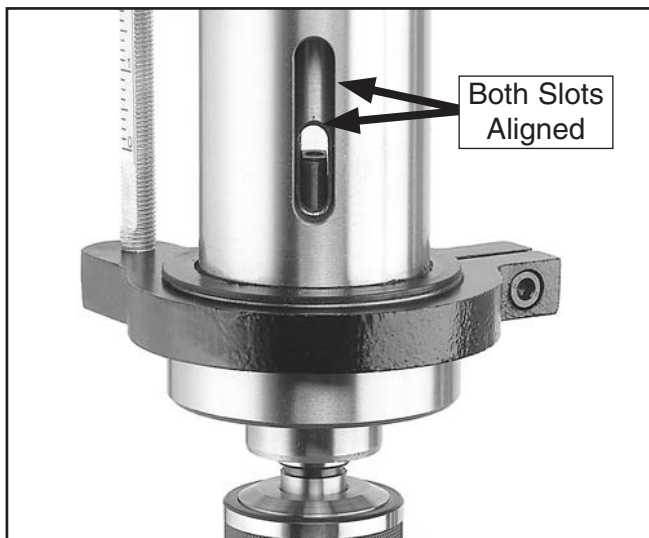

Figure 31. Inner and outer drift-key slots aligned.

7. Hold the drill chuck with one hand, and tap on the drift key with a rubber or wooden mallet, as shown in **Figure 32**, until the chuck releases.
8. Hold a downfeed handle with one hand, and loosen the depth stop lock with the other hand.
9. Carefully retract the quill into the head stock.



Figure 32. Using drift key to remove arbor.